

*Forged &
machined
parts*

Stampal SB

impol
Aluminium Industry



Our Passion. Innovation.

The processing of aluminium into state-of-the-art semi-finished products is our business and our passion. For almost two centuries, we have been guided by innovation, development orientation, flexibility and universality.

Our sustainable business growth, our continuous modernisation and expansion of business capacities, and our wide range of products and alloys represent a guarantee that you will find us a reliable business partner.

The company Stampal SB is an aluminium forging company. We should declare ourselves as a “young company with old experience”, which was bequeathed to us by our founders. Our strategy is long-term cooperation with our customers from development to the production of parts.

FORCE RANGE

0.45-1.8 MN

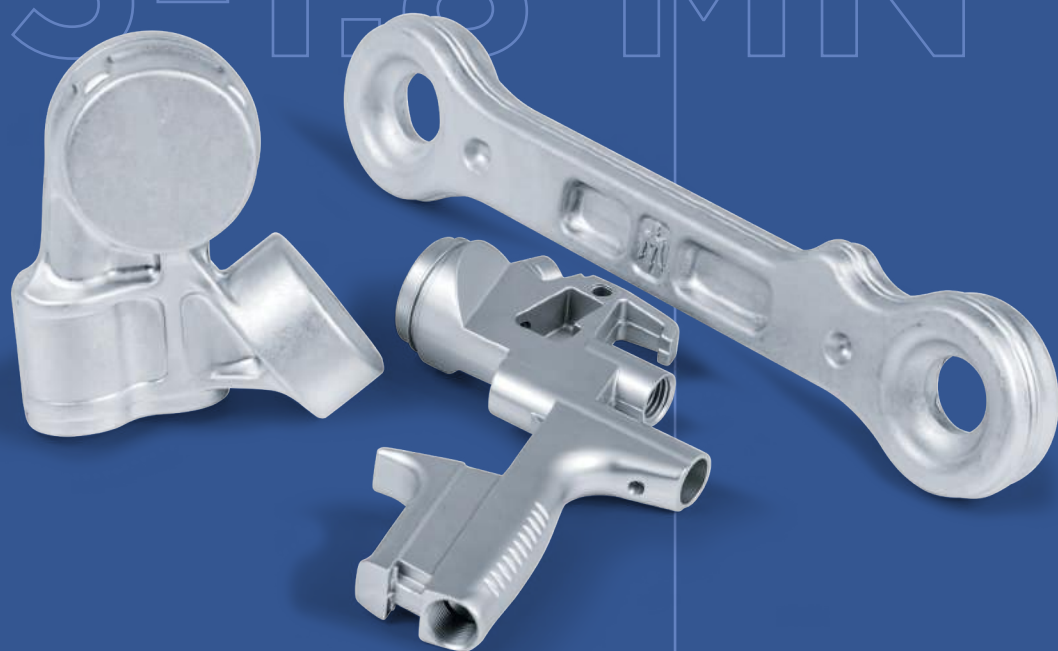

5 million
forgings

flexibility

A young company with old experience

Our activity is hot forging, which has long been used on an industrial scale for forging aluminium alloys.

We have a wide range of forgings available, including those considered D-parts. This label signifies products that are essential for safety and, therefore, must be documented accordingly. Our forgings stand out in their dimensional accuracy and their excellent mechanical properties.

All processes are thoroughly planned, executed and monitored. Statistical methods are applied for production control.

We produce approx. 3 million different forgings per year. For tooling, we collaborate with toolmakers, who not only make sure the delivery periods are kept short, but also ensure excellent quality to enhance our flexibility, which itself is of primary importance for success on the market.

A WIDE RANGE OF ALUMINIUM ALLOYS

FROM 2xxx TO 7xxx

Process

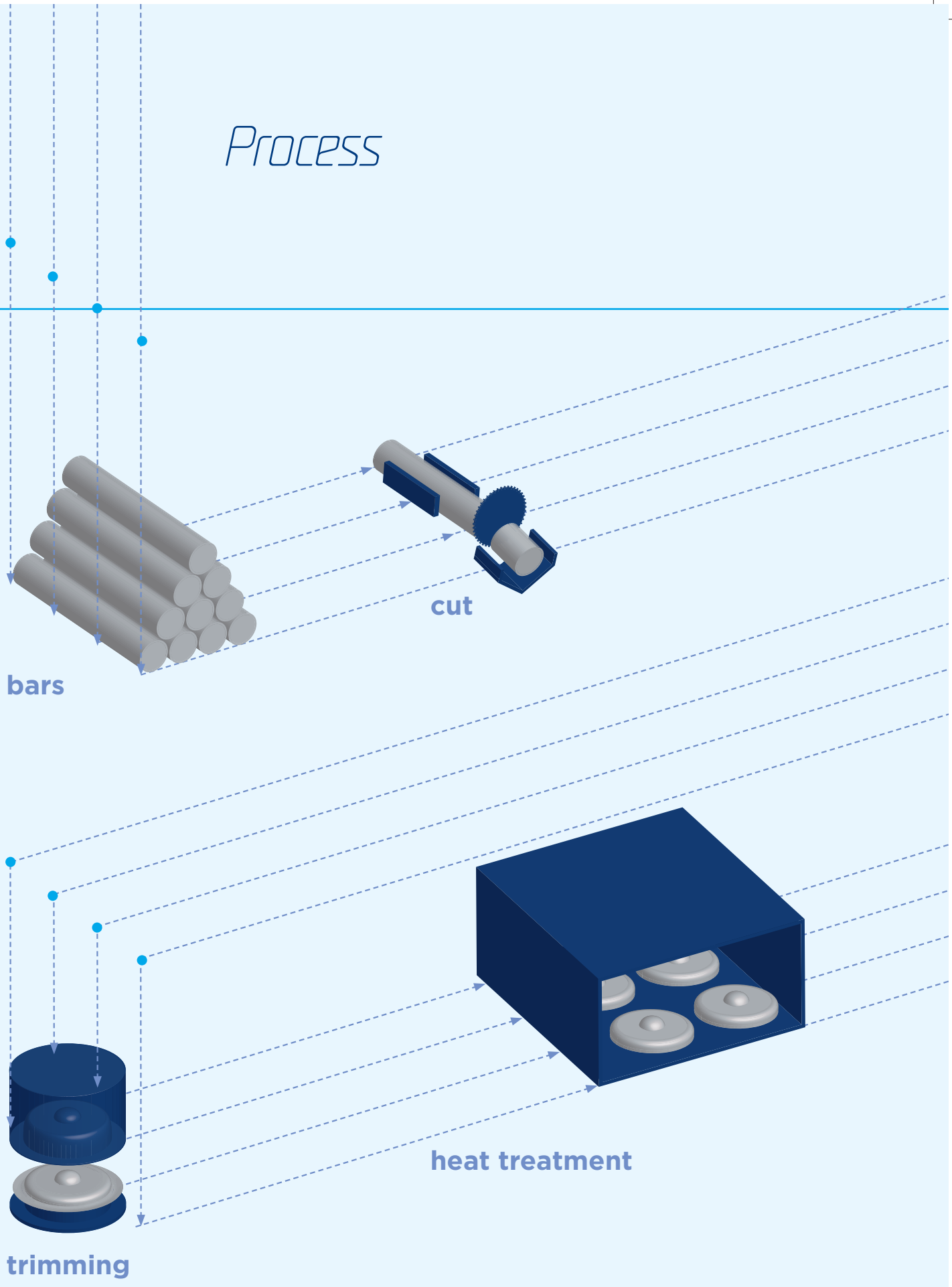

forging

tumbling & pickling

visual inspection

CNC

packaging

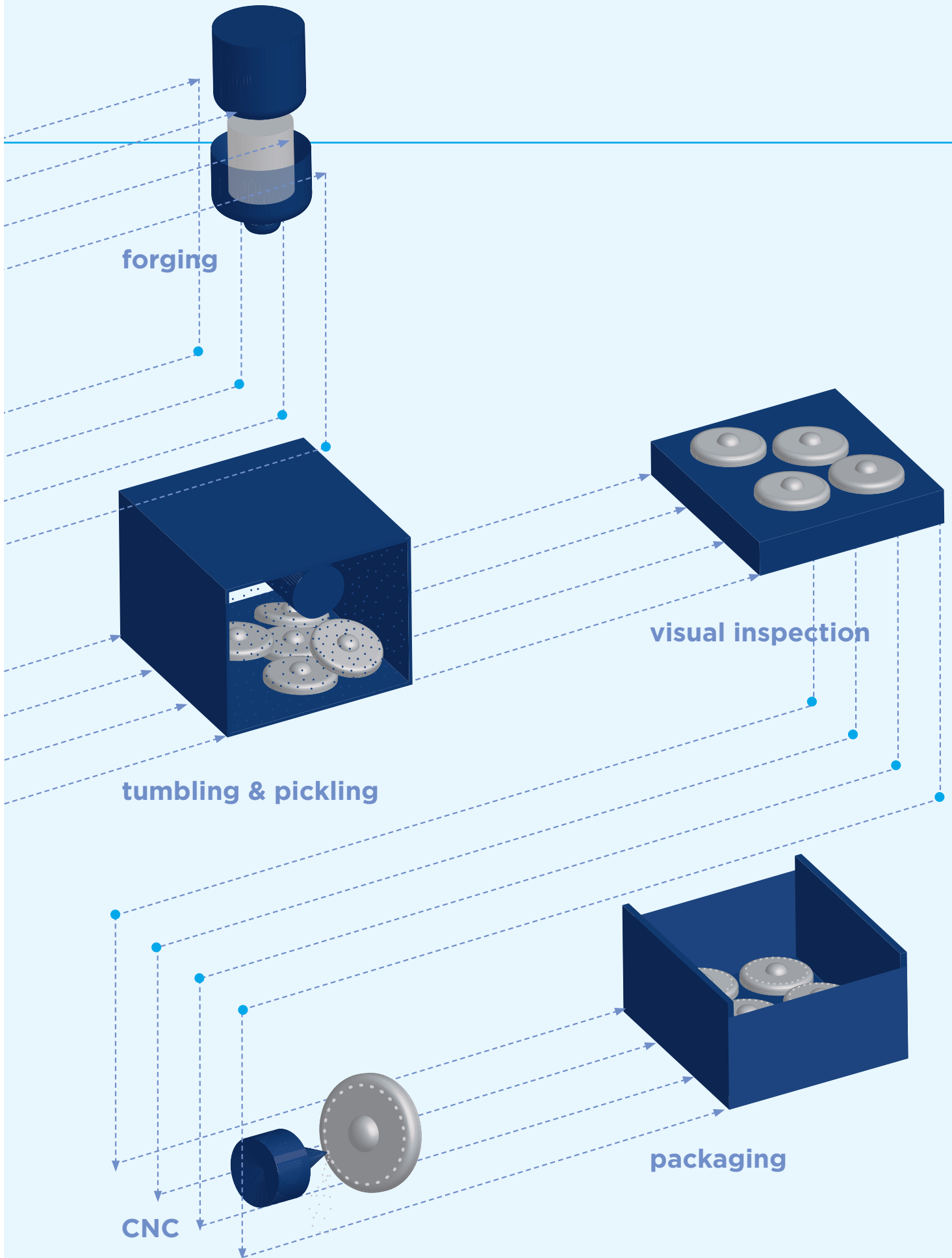

ISO 9001:2015

BVQI SINCE 2011



alloys	norms	tensile properties			
		Rm [N/mm ²]	Rp 0.2 [N/mm ²]	A 5 [%]	HB
P Al Cu 2.6 Mg	2117	320	260	8	100
P Al Cu 4.4 Mn Mg	2014	450	385	5	125
P Al Cu 4.4 Mg Mn	2024	395	260	9	100
P Al Cu 5.5 Pb Bi	2011	335	225	12	90
P Al Mg 0.5 Si 0.4 Fe	6060	185	135	9	55
P Al Mg I Si Cu Cr	6061	265	240	8	85
P Al Si I Mg Mn	6082	310	260	6	90
P Al Zn 4.5 Mg	7020	345	265	8	100
P Al Zn 5.8 Mg Cu Cr	7075	510	435	6	140
P Al Zn 6 Mg 2 Cu I Zr	7012	510	470	7	150
P Al Zn 5.8 Mg 0.8 Zr	7003	320	210	10	90

Uncompromised Quality

015

The quality of our products is subject to certification and testing in the state-of-the-art independent labs of the Impol Group, i.e. the labs for metallurgical, metallographic and chemical testing.

THE METALLURGICAL TESTING LAB

It conducts mechanical tests, hardness tests and tests of the material's hard-drawing properties. Keeping up with the latest findings in the field of testing, we are consistent in implementing the most recent standards in our testing methods.

The metallographic testing lab is concerned with analysing the material's history and characterising the segments of its microstructure. Metallographic analysis is conducted via optical microscopy. Electron microscopy featuring an EDS detector is used to produce more reliable results in terms of identifying the type of material and individual fragments.

THE CHEMICAL TESTING LAB

It carries out spectroscopic analyses of the chemical composition of aluminium alloys, analytical chemistry and waste water analysis.

CERTIFIED QUALITY

We are an ISO 9001:2015 certified company. Quality is our main priority and a central feature of our corporate philosophy. We always make sure we exceed customer expectation on the quality front. Our vision is to achieve optimal quality for the appropriate price on the marketplace.



*Aluminium is a reason
to believe in a zero
waste future.
About 75% of the
aluminium produced at
any time is still in use.*



ISC

Environmental care

Forged aluminium parts have the reputation of being the products of the future mainly due to their environmentally friendly processing, use and recycling. We are ISO 14001:2015 certified.

ISO 14001:2015

BVQI SINCE 2010

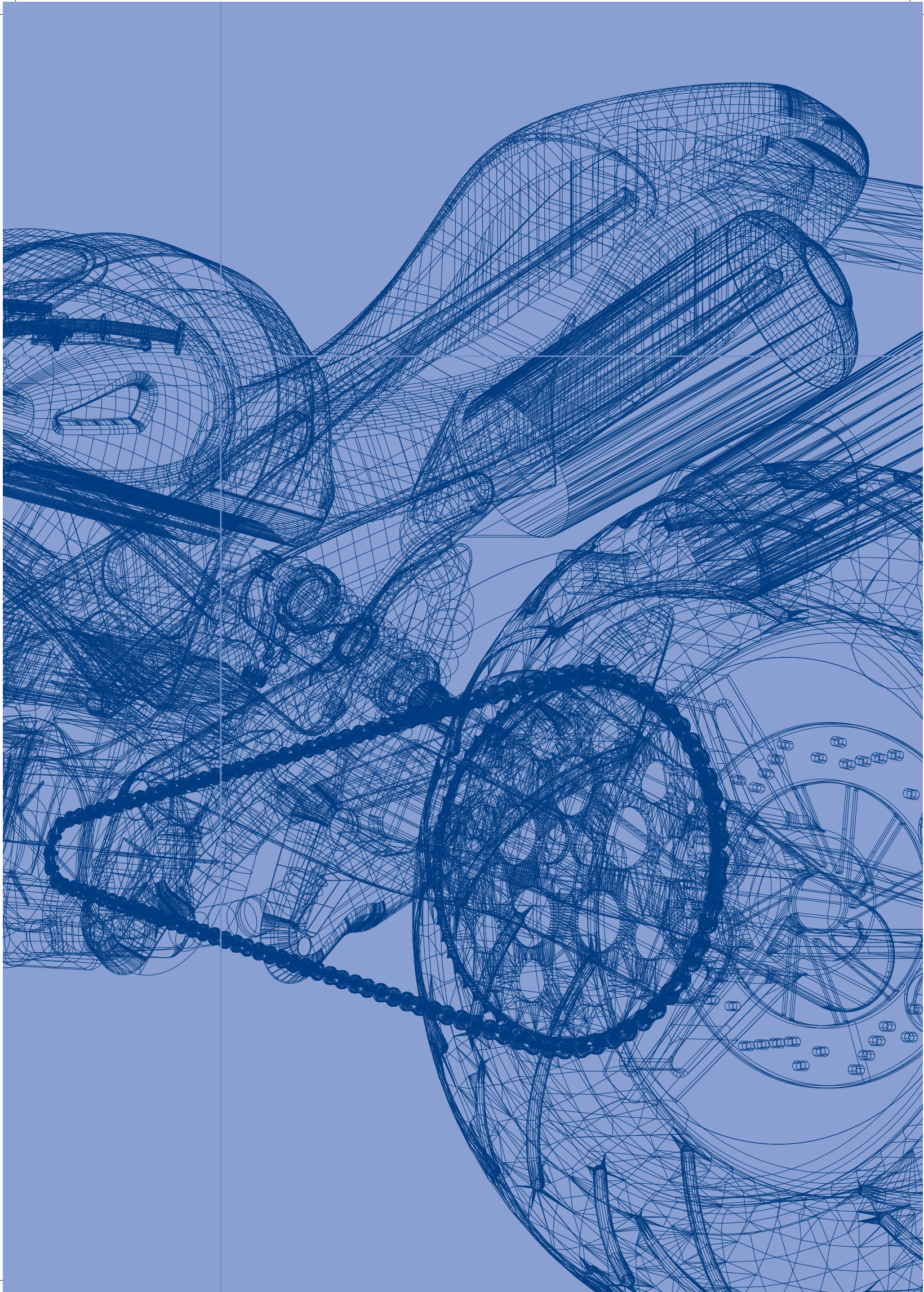

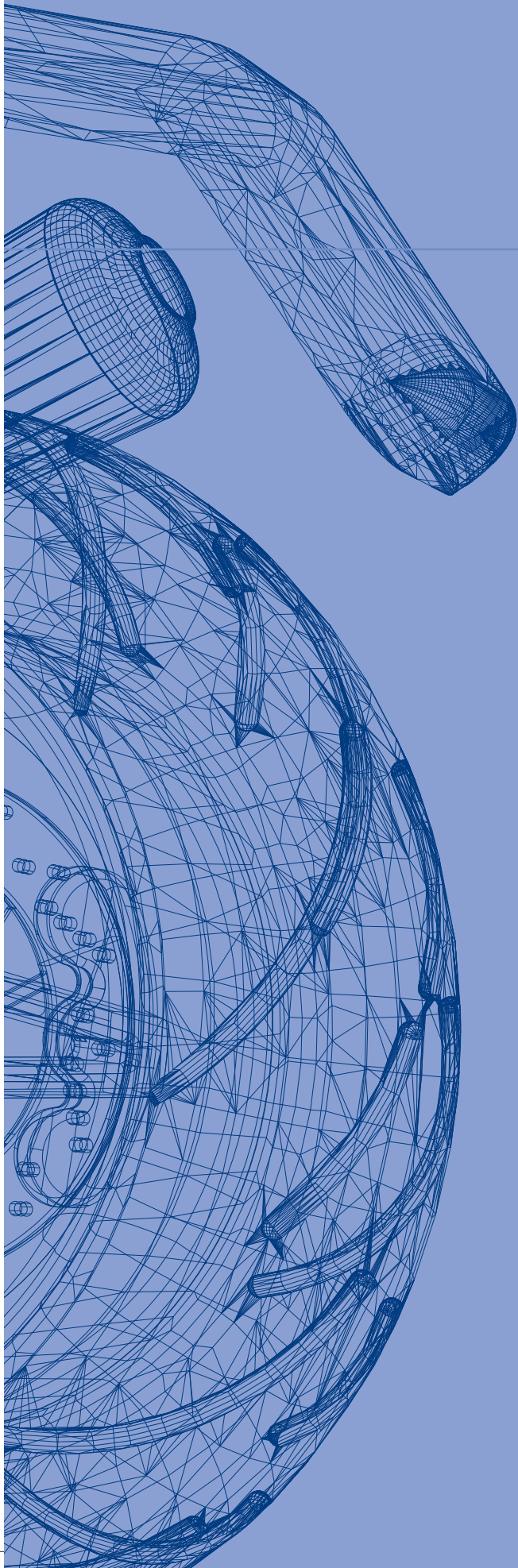

*Parts for
motorcycles*



zero
defects

HIGHLY VISUAL COMPONENTS

The motorcycle sector represents our core business. We supply our finished components to all European manufacturers directly or indirectly through our partners for machining. Normally parts are highly visual components, which requires a surface free from any minor nonconformities or defects.

visual components

LOYAL CUSTOMERS/PARTNERS



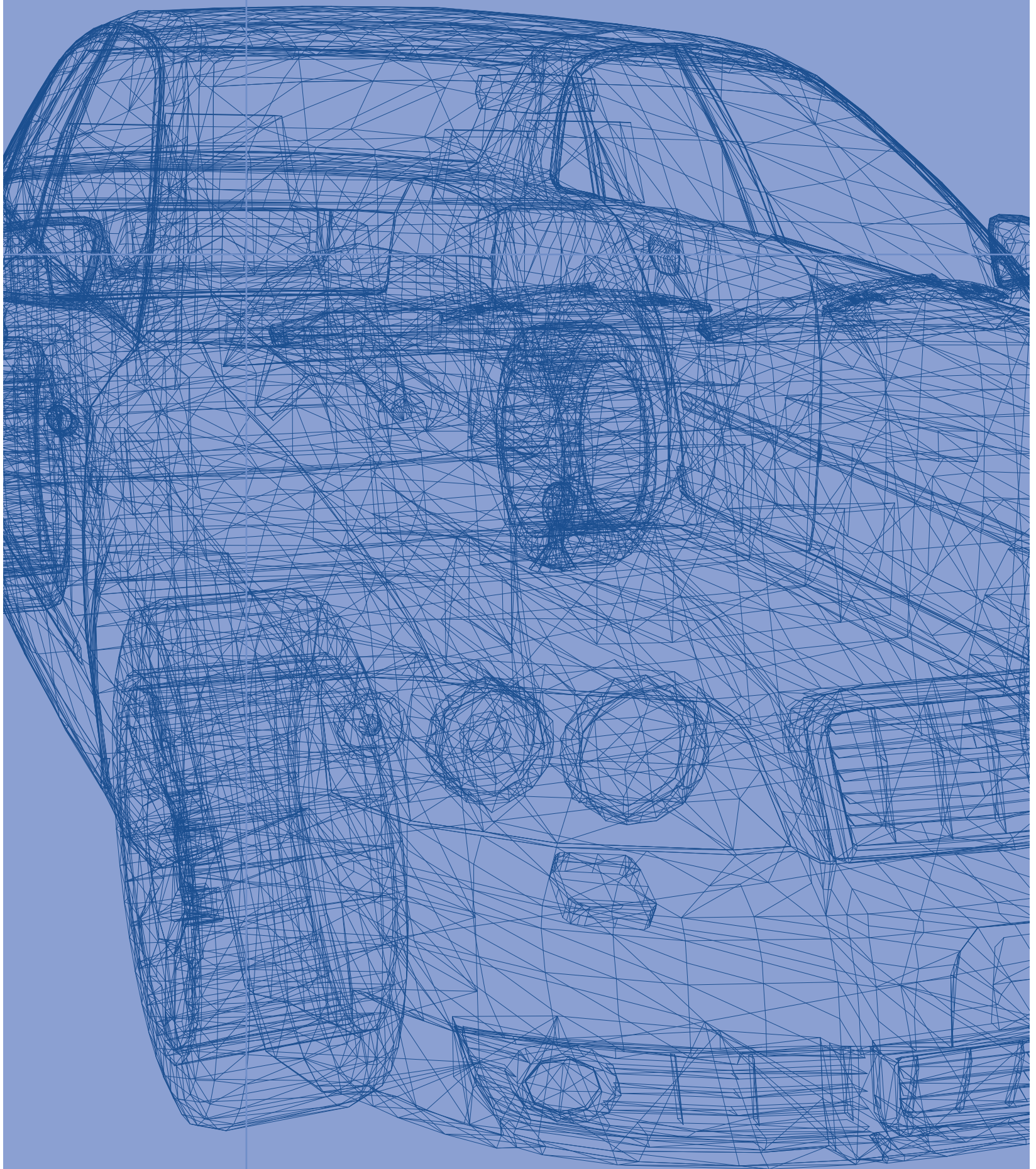

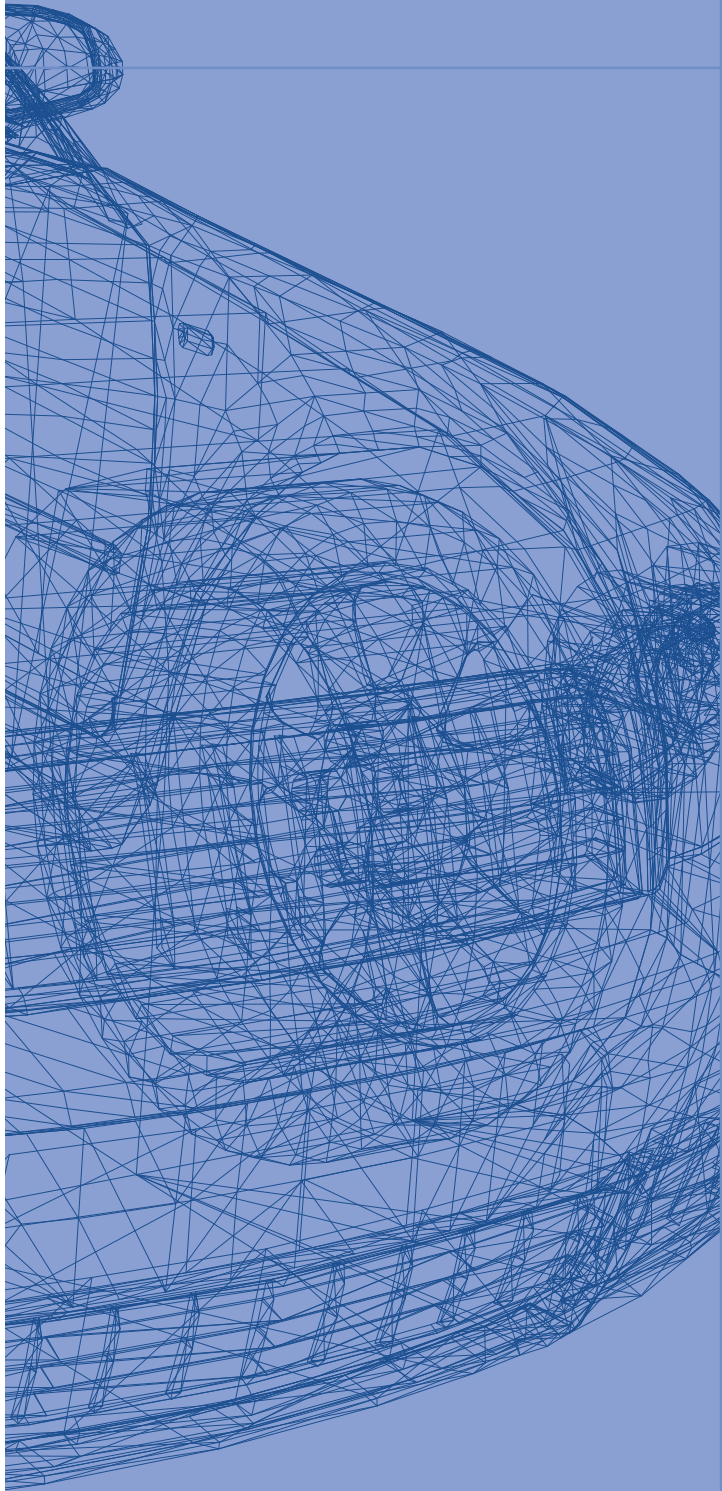

Automotive parts



extreme
demand

EXTREME MECHANICAL PROPERTIES

The rapidly growing trend of aluminium blanks in the automotive sectors is also reflected in our company. Each year we increase the number of components produced for new cars.

We collaborate with producers of low volume luxury cars with extreme demands. Normally we manufacture safety components for engine, suspension, transmission and brake systems. Higher mechanical properties than standard were developed in order to meet the requirements.

luxury cars

LOYAL CUSTOMERS/PARTNERS



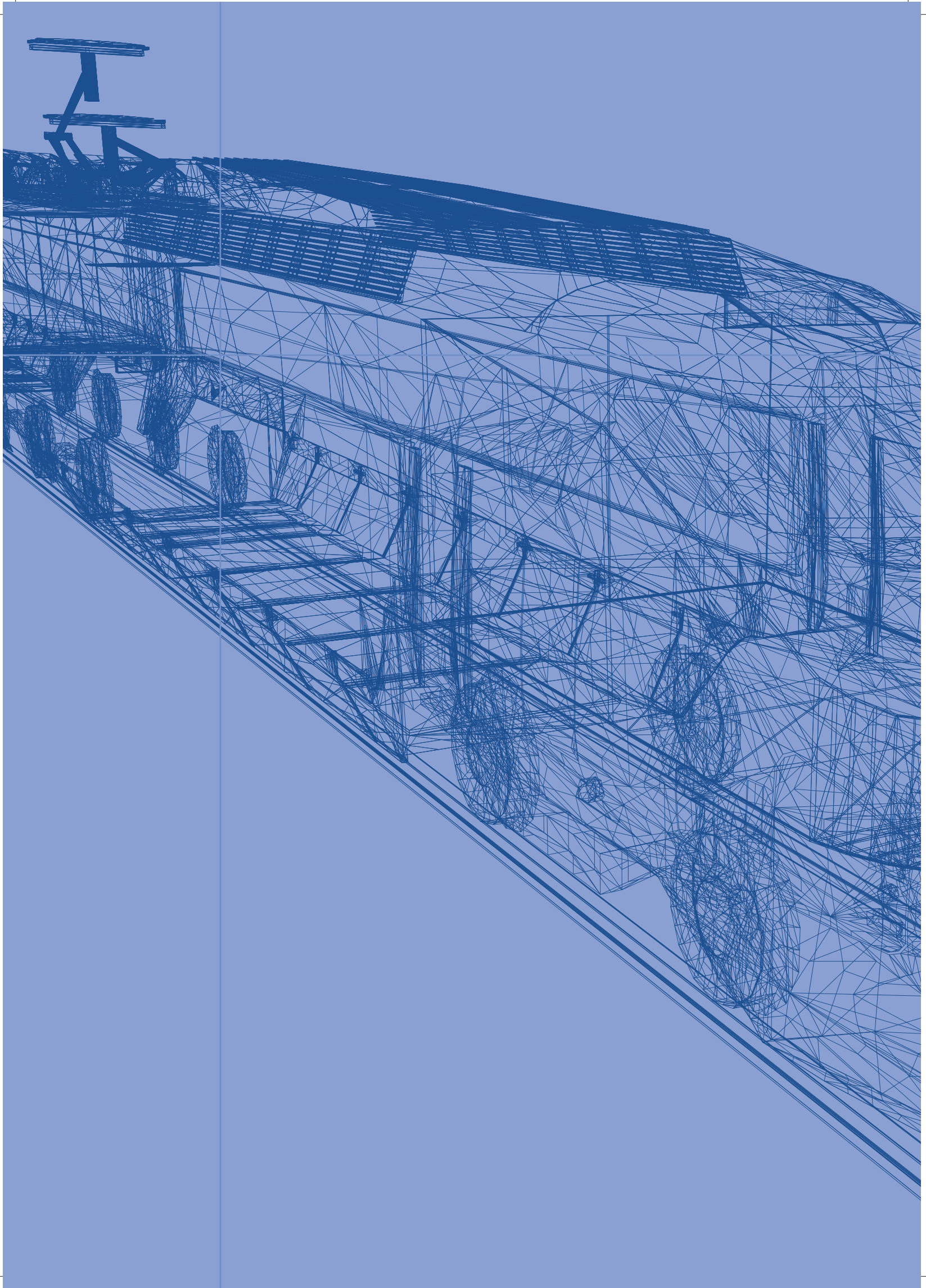

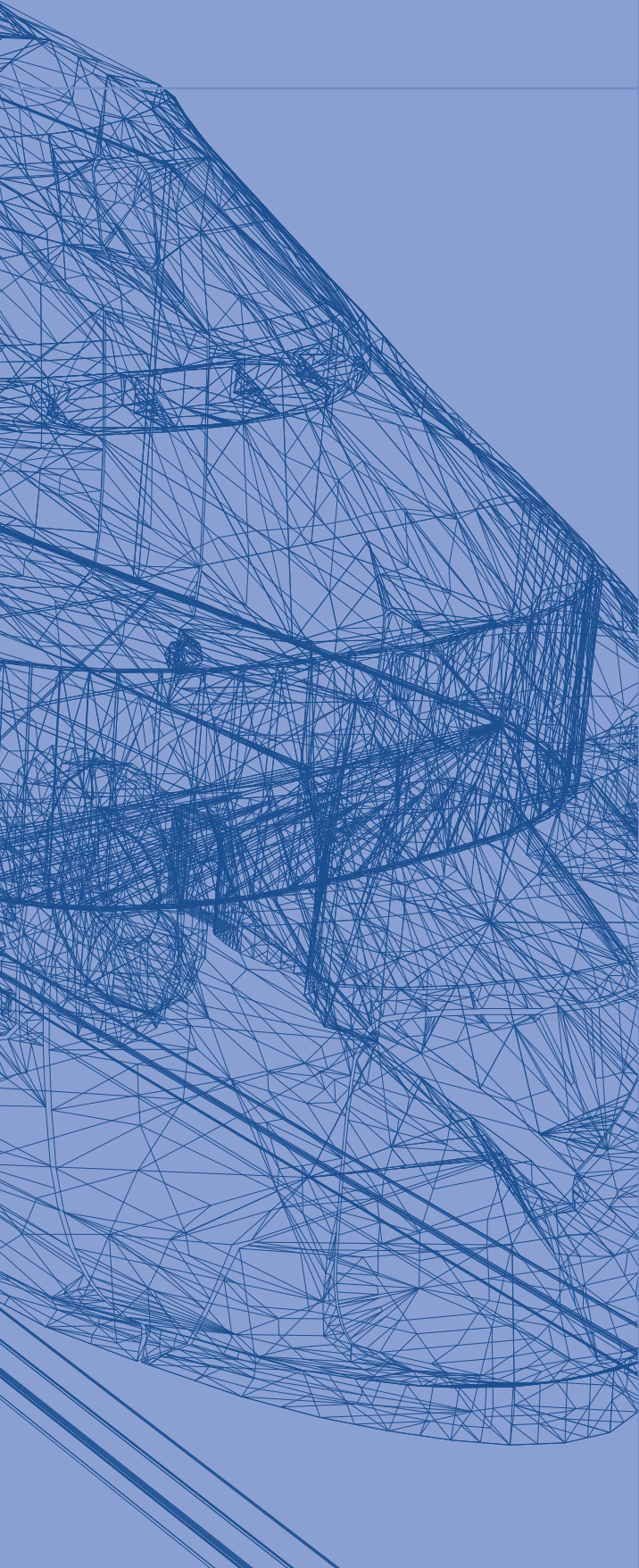
A complex wireframe mesh of a mechanical part, likely a compressor component, rendered in a light blue color against a darker blue background. The mesh is composed of numerous interconnected lines forming a dense, three-dimensional structure. The part has a curved, cylindrical-like shape with various internal and external features.

*Parts
For the
compressor
industry*



A VERY IMPORTANT SECTOR

A significant percentage of our production is dedicated to the compressor industry, mainly compressors for various refrigeration applications. The main products are connection rods and valve housings.

refrigeration applications

LOYAL CUSTOMERS/PARTNERS



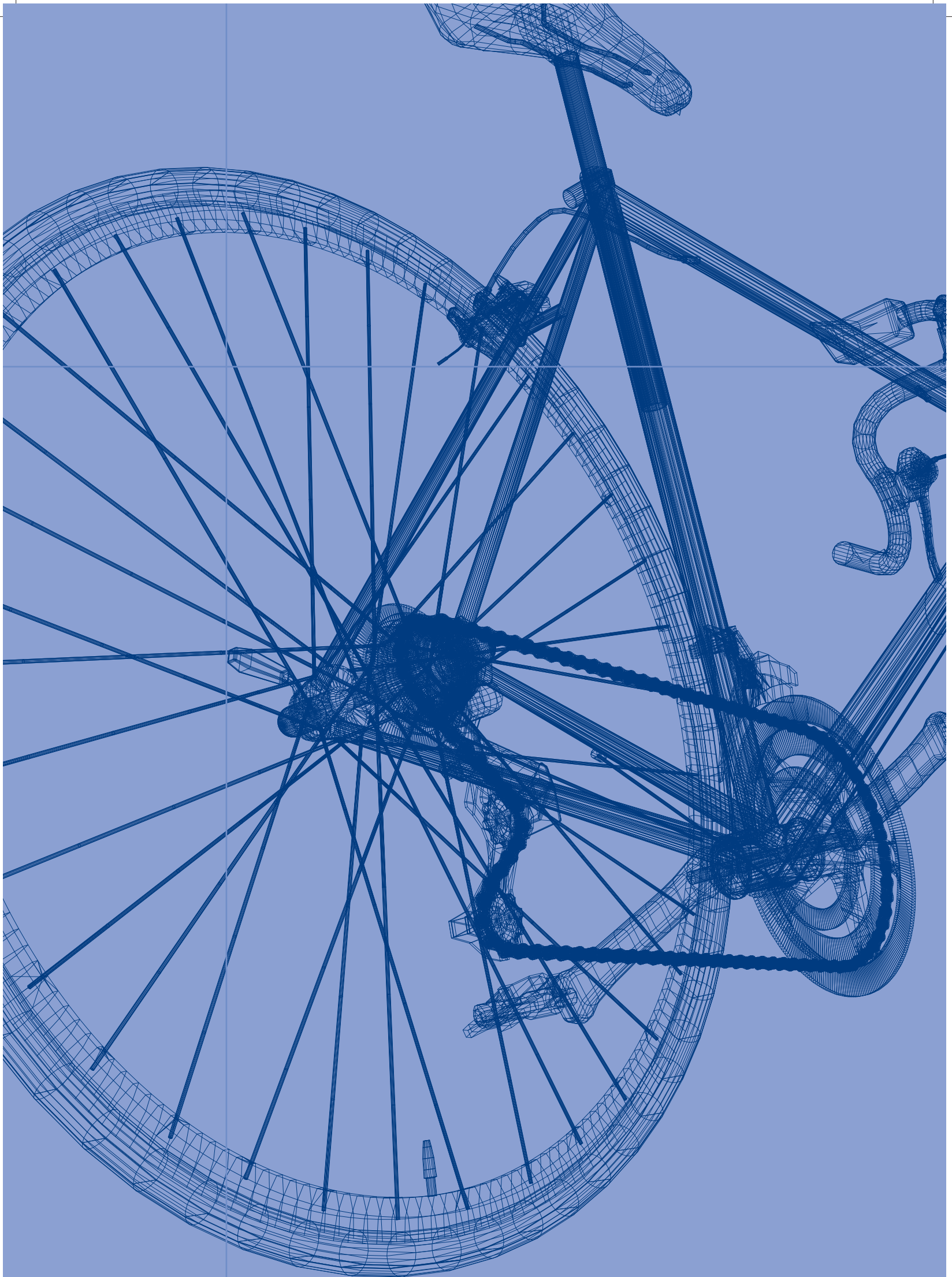



*Parts for
bicycles*



crank pedals

FATIGUE

On bicycles, aluminium forging technology has been used for several decades. Aluminium components are used because they guarantee a good compromise between high mechanical properties and weight. From the commercial point of view, they are more economical compared to composite material, like carbon for example. Our most important product in this branch is our crank pedal.

brakes

LOYAL CUSTOMERS/PARTNERS

Campagnolo

MICHE

F **FORMULA**



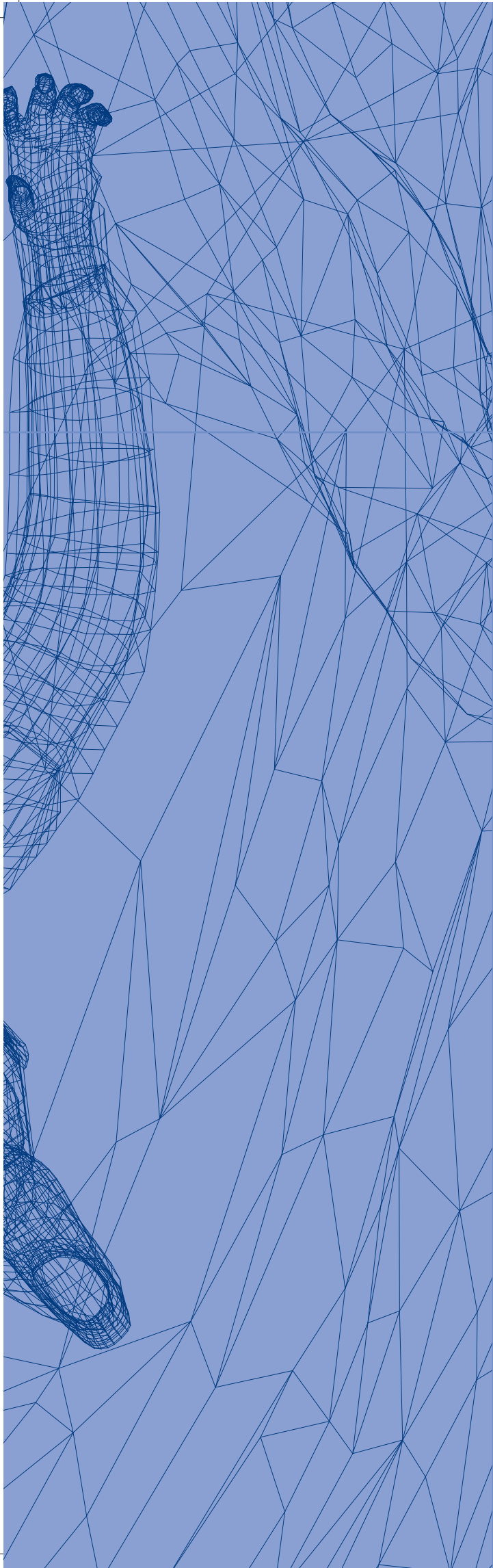

*Other
forged
parts*

sport

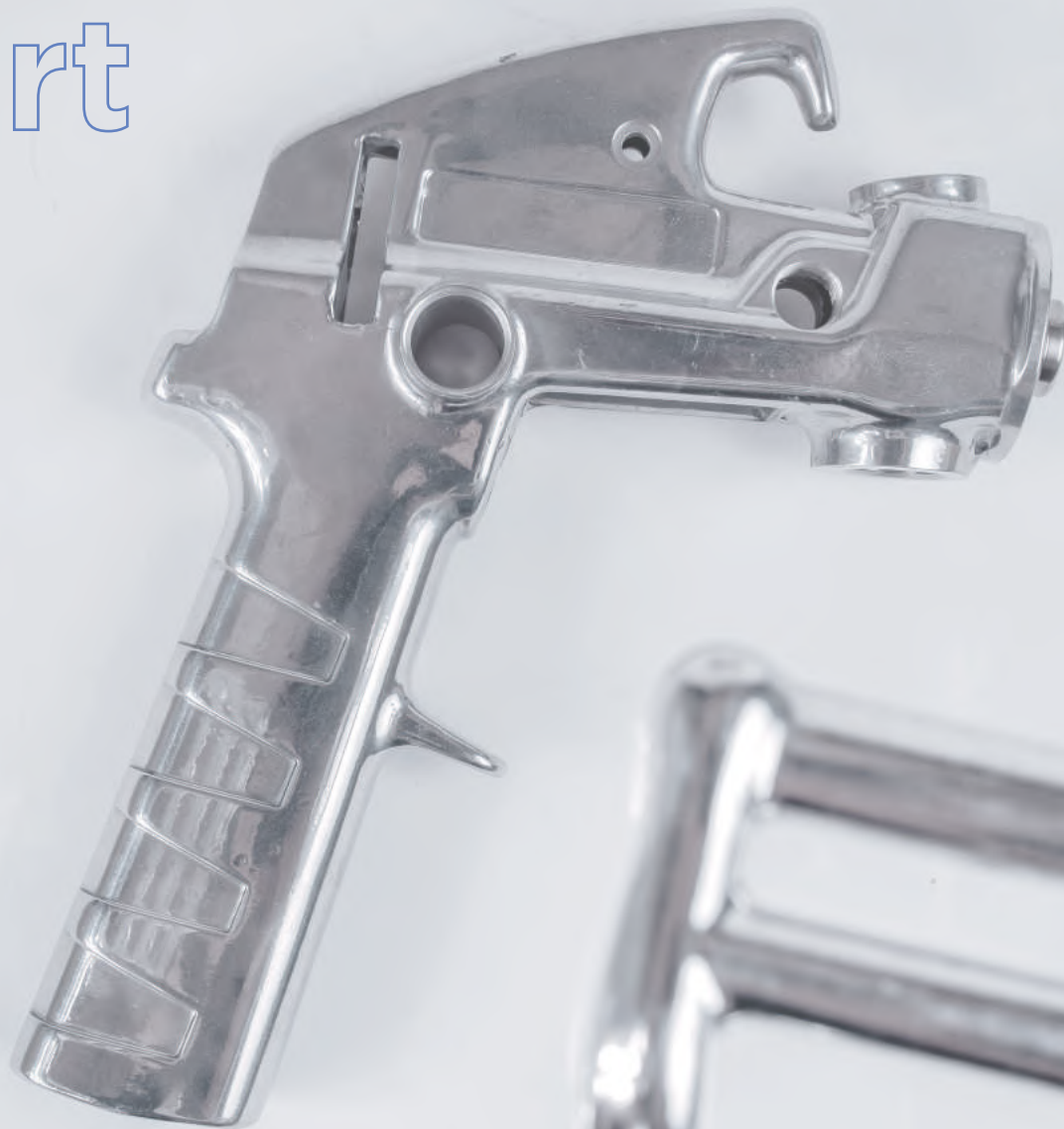

OTHER BRANCHES

A significant percentage of our market covers other branches. It is necessary to emphasise the sports sector (climbing), the armament sector and the sector of spray guns. They are specific from different points of view and are therefore very demanding and tricky. A lot of flexibility with the shortest possible developing time is expected.

painting

LOYAL CUSTOMERS/PARTNERS





*We could declare ourself
as a "young company with
old experience", which was
bequeathed to us by our
founders!*







*Our production can be
customised to meet
the customers' specific
needs.*





Stampal SB

Partizanska 38
2310 Slovenska Bistrica, Slovenia

T: +386 2 80 55 440
F: +386 2 80 55 449

stampal@stampal-sb.si
www.stampal-sb.si

